

# STRATEGIC PLANNING OF EMERGENCY AREAS FOR TRANSITIONAL SETTLEMENT

**Roberto Bologna**, Dip. TAeD, Via San Niccolò 93 - 50125 Firenze (IT)  
roberto.bologna@taed.unifi.it

**Department of Architecture and Design Technologies "P. Spadolini",  
University of Florence**

## **Abstract**

**In emergency conditions, the realization of a settlement develops according to an unplanned process then affecting the transformation - often permanent - of places through the imposition of uncodified rules. The research here set forth proposes criteria and guidelines for the planning of transitional housing settlement areas in order to effectively meet the requirements of emergency prevention and post-disaster reconstruction through a coordinated approach among land/town urban planners, emergency planners, disaster managers, users.**

**The main topic is presented by following the study progress through the phases which have led to the final results. At the same time, the sequence of the single conceptual elements is based on the logic of problem-solving, as required in an architectural project so as to facilitate the interpretation by part of the final users. We believe that the research most important contribution is represented by the analytical approach towards the problem, which is based on a culture of the project, rather than on the mere identification of the technical standards.**

**The research outcomes are represented by a framework of possible design solutions that verify the settlement patterns depending on the characteristics of the area and the size of the population. The research product is a transitional settlement planning guide to be used by local land authorities.**

*Keywords: shelter areas, emergency, temporariness, settlement, planning.*

## **INTRODUCTION**

The Italian Civil Protection regulations have increasingly evolved commencing from the release of the outline act n. 225 of 1992, up to the precise organization of the operational functions as proposed by the so-called "Metodo Augustus" of 1997. This progress has then produced a complex codification of the procedures for the activation of the emergency civil protection system. Within this legislative framework, specific provisions have been implemented to create the initial conditions for the preparation of the areas of transitional settlement, in particular the protocol note 3089/065 EMER of 8th July 1997, in which local authorities are invited to identify the area for early welcoming and the setting up of housing modules in case of emergency.

Upon a series of legislative provisions, the legislators have identified the main criteria for these areas, considering multiple factors and other peculiarities. The Regione Toscana has adopted these criteria - in particular, that one referring to the area multi-functionality - by act of the resolution n.495/97 entitled "Technical instructions for the urban planning of multifunctional equipped areas of public interest". The intention of the resolution is that of defining specific technical parameters and the methodologies for the elaboration of the urban decisions which local authorities must introduce to regulate the areas of public interest. As specified in the resolution, these areas are devoted to the supervision, coordination and execution of the first-aid operations and life support to the population by part of the Civil Protection task force, in case of emergency.

In order to boost the selection and restructuring of the areas destined to the transitional settlement of housing systems during an emergency situation, the Italian Department of National Civil Protection has provided for a series of "guidelines for the identification and the realization of the shelter areas and the installation of prefabricated buildings for civil protection". These guidelines have currently been approved in technical terms by the Italian Conference of the Regions to the purpose of defining a consistent organizational pattern in terms of housing protection for the population affected by a catastrophe.

Although the legislative foundations have been laid, today we must still define the projecting criteria to configure the temporary settlement of first-aid and rescue areas in case of emergency and to design the relevant technical instruments for the application. In addition to an in-depth knowledge background, the research has been developed in the light of the recent evolution trends, which are modifying the cultural approach to the issue of transitional housing settlement in case of emergency (Bologna 2002, Bologna and Terpolilli 2005).

## **GUIDELINES FOR THE PLANNING OF EMERGENCY TRANSITIONAL SETTLEMENT**

The research team is composed by a group of researchers from the Dep. of Architectural and Design Technology (Prof. Roberto Bologna scientific manager, Prof. Carlo Terpolilli, Arch. Francesca Burdisso, Arch. Lisa Casucci, Arch. Antonella Cesaroni, Arch. Stefano Combet), under the supervision of the superintendents of the Structural Interventions and Emergency Works Office of the National Department of Civil Protection at the Italian Government (Eng. Corrado Seller, Eng. Pasquale Gidaro) and of the Regional Division of the Civil Protection System at the Regione Toscana (Eng. Alessandro Guarducci).

The research team has made every effort possible to open a discussion with the direct users of these guidelines in a final applicative phase. This projecting laboratory has included a representative sample of members from the Local Authorities which mostly characterize the national situations. The laboratory objective has been to test the investigations results directly into the field and to contribute to the perfecting of the operational instrument.

Objective of the Local Authorities here represented has been that of creating a "handbook" of operational instructions to be used as a reference for the civil

protection divisions at the Italian cities/towns which are responsible for the definition of specific plans for the housing of transitional shelter areas in case of emergency. The operational instrument resulting from this research is represented by the guidelines for the planning of transitional settlements during an emergency event and the identification of the urban planning parameters referred to the Transitional Settlement System as a dimensional reference, to guarantee the satisfaction of the functional and, above all, the psychological and social requisites. One of the guidelines focuses is the area infrastructures, which are assumed to be characterized by two modalities: *permanent infrastructure* and *temporary infrastructure*. A permanent infrastructure is meant to be the essential one as it guarantees the immediate setting up and functioning of a transitional settlement in case of emergency (primary road network, primary water and power plant, primary drainage and sewer system), and also the compatibility with respect to the specific usage destination expected in ordinary times. The area permanent infrastructure is conceived as an adaptable network in relation to the possible solutions of the first-aid system, which derive from the application of the different housing models defined in the guidelines. The technological dimension of the primary infrastructural networks can therefore comply with the functions generally assumed by the area during peacetime (a parking area, a green fully equipped area, a market, etc.) with the installation of a power and a road network, a parking area and a public green recreational park. While for temporary infrastructure, we mean the temporarily housing settlement during an emergency or catastrophic event, in which the connection of the transitional housing units to the pre-installed primary networks is required. Once the transitional housing units are not urged any longer, the temporary infrastructure shall not undermine the re-settlement of the area to the ordinary functions.

## **Transitional Settlement System**

The approach used to identify the functional features and the project requirements of the Transitional Settlement System is based on the meta-designing methodology and on a need-performance logic, in order to achieve the definition of a framework of project requirements and the identification of satisfaction and performance standards to be referred to by the designer during the settlement projecting phase.

The Transitional Settlement System includes 3 subsystems:

- 1. *Transitional Housing System,***
- 2. *Transitional Community System,***
- 3. *Services or Shared-Facilities System.***

Each subsystem is organized into *Spatial Units*, grouped according to different categories. The Spatial Units are organized on the basis of their usage into Private Functions, Semi-private Functions and Public Functions.

For each Spatial Unit a series of *Basic Activities* are identified, which are grouped on the basis of their priority into Basic Functions and Optional Functions, according to an urgency scale.

For the single Spatial Units and for the whole Transitional Settlement System, we also identify a number of *Project requirements*, which are aimed to meet the typical problems related to temporary housing under emergency conditions:

- Enhancement of the life quality in terms of environmental well-being,
- Psychological support to final users,
- Implementation of adequate dimensional standards for the housing and service functions,
- Organization and differentiation of the usage modalities and space allocation,
- Importance of the local context social and environmental factors,
- Alternative usage of the areas,
- Reconversion and temporariness intervention criteria,
- Sustainable development.

At this point, it is important to underline that the knowledge and expertise required for the definition of the satisfaction and performance standards are derived partially from other previous studies in this field and partially from the instructions provided by the existing legislation material, but, above all, from a direct survey on the field, as application of the Post-Occupancy Evaluation methodology used after the earthquake event of 1997 in the territory of the Marche and Umbria regions (Bandini and Burdisso 1999, Bologna 2001).

### **Minimal Housing Unit**

The basic element of the Transitional Housing Settlement System is the **Minimal Housing Unit**, which is structured as follows (Fig. 1):

1. *Confined space:*

- Housing Module (MA).

2. *Exchange area of the housing module:*

- Entrance / Path (ING),
- External Housing Area (AEV),
- Service Area (AS),
- Storage Area (D).

3. *Complementary facilities:*

- Neighbourhood unit (UdV),
- Parking area (P),
- Unbuilt green area,
- Road network.

The dimensional characterization of the Minimal Housing Units is based on the temporal development of the settlement process in two subsequent phases: this occurs today with the passage from the container (mobile unit ISO 20, 6x3 meters, 1/2 individuals, or unit ISO 40, 12x3 meters, 3/4 persons) to the prefabricated house (wooden prefabricated unit, 8x6 meters, and unit type DPC 40 for 1/2 persons, or unit type DPC 50 for 3/4 persons) in order to guarantee the interchangeability on the lot.

The surface of the Minimal Housing Unit components varies according to 2 criteria: the dimensional parameter is "constant" and "variable" in function of the changes in the Housing Model and in the Aggregational Typology.

The variable oscillates within a set range of values: this does not depend on the designer's arbitrary decision but it is strictly connected with the preventive decisions taken in relation to the Housing Model and the Aggregational Typology.

To sum up, it is possible to say that confined space and exchange area represent the dimensional constants, while the so-called Complementary Facilities suggest the dimensional variables.

Moreover, the definition of the dimensional constants refers to functional-distribution criteria, while the dimensional variables refer to socio-psychological criteria. In other words, the dimensional constant values determine the surface levels required for the execution of the Basic Housing Functions, while the dimensional variable values determine the Optional Housing Functions.

Fig. 1 - The elements of the Minimal Housing Unit (example of the Module "container" for 3/4 users)

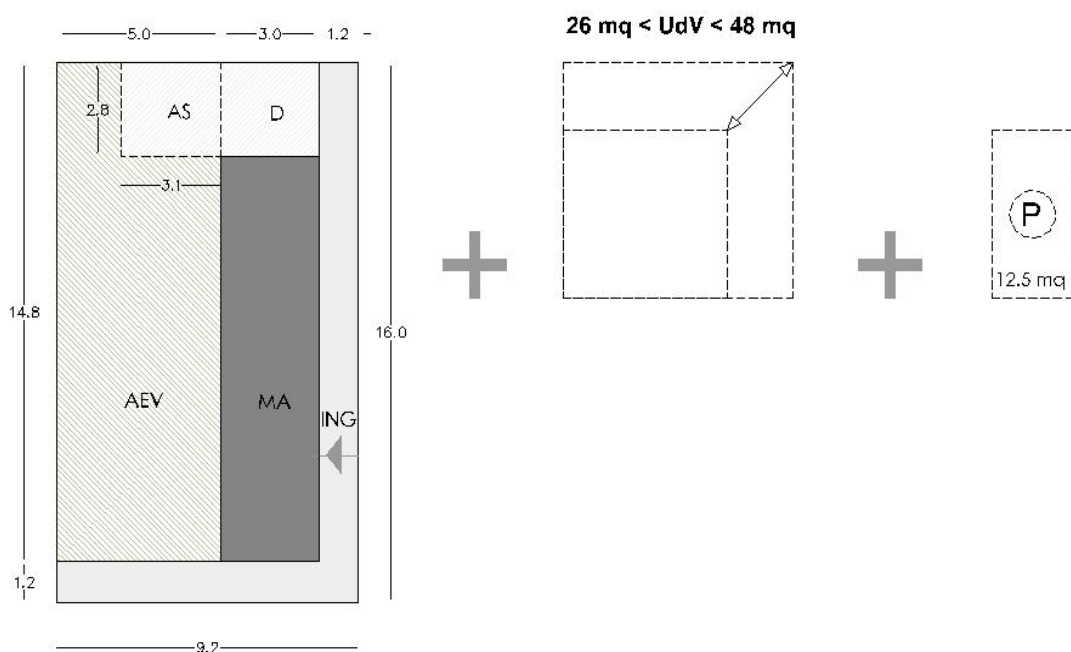

### Basic Aggregative Typologies (formation of the urban fabric) and Aggregation Minimal Units

The study of the aggregational rules in the Minimal Housing Unit determined at the morphological and dimensional level leads to the definition of a basic block, that is the **Minimal Aggregational Unit** (Fig. 2) of the transitional settlement fabric.

The analysis is carried out along two frontlines: on the one hand, the survey on the historical-social reference material; on the other, the definition of the buildings block at a morphological-dimensional level to establish the number of modular units composing the block and, thus, the minimum social aggregate. All this is developed starting from considerations related to functionality and distribution and, also, upon social-anthropological considerations.

The most relevant cultural-historical reference is represented by the urban models of the "foundation cities", as this model can effectively apply to the interpretation of the emergency transitional housing settlement, even though for a more contingent usage. In historical cities (Caniggia and Maffei 1996, 1999), buildings are positioned according to specific urban plans regulating the realization of an *aggregate*. The concept of urban aggregate has evolved in the course of the centuries, drawing from its extended evolution and history a system of building rules which regulate the formation of the *urban fabric*. The fabric is the concept of reciprocal proximity among different buildings positioned within a network of numerous ways, determining the changes of the urban aggregate. Buildings can assume a large variety of functions, and thus we can obtain a basic housing fabric or a services-oriented fabric. In this study, aggregational typologies belonging to the Italian historical urban tradition are referred to, defining its cultural elements. In Italy (Caniggia and Maffei 1979), the urban planning tradition of the historical centres is determined by the serial collocation of buildings, which are organised into 3 **basic aggregative typologies** modifiable in function of the system requirements of the area affected by the catastrophe, for the purposes of this research:

- **ROW HOUSING**, characterized for the positioning of the larger module parallelly to the lot depth, with one short side facing the road and the other opening on the exchange common area (neighbourhood unit). This area is structured as a green and services-destined area, and is enclosed between a determined number of housing units.
- **COURT-ROW HOUSING**, repeats the aggregational pattern of the row housing, where the positioning of the module is changed, with the major side opening on the road; a back space is thus enclosed as in a court.
- **COURT**, is created from the organization of the minimal housing units in an all-side delimited block. The housing modules are positioned closely with the longest side opening on the road; the enclosed structure determines an internal space for the exclusive use of the inhabitants (neighbourhood unit) like the ancient Roman patio.

Fig. 2 - Minimal Aggregation Units (example)

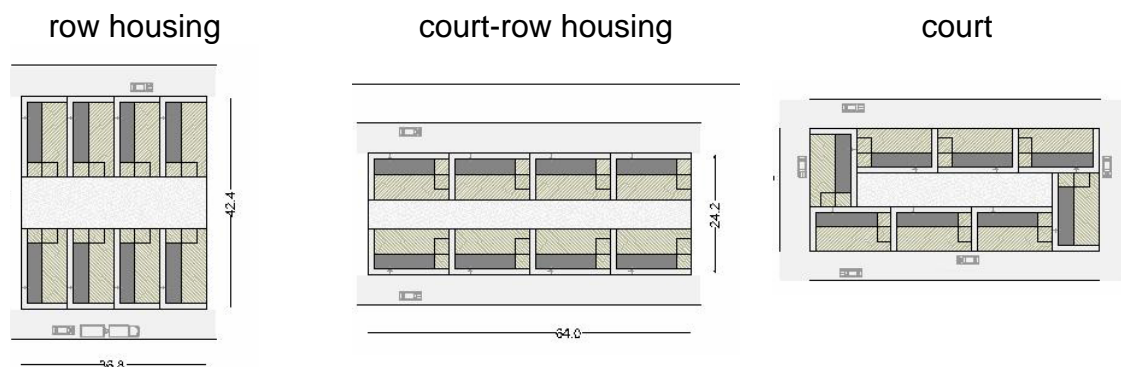

At a dimensional level, each of the three aggregational patterns (row, court-row, court) can assume 3 different compositions made of 6, 8, or 12 housing modules,

respectively. Nine minimal housing units are therefore created at a theoretical level, but seven in the practice, as two composition solutions are not consistent. Even in this case, the Minimal Aggregational Units are preserved during the 2 phases of the settlement process as the interchangeability between the container and the prefabricated house is realized with no changes to the pattern.

### **Context conditions**

The main data of the application context where the transitional settlement is realised are the following ones:

- **area characteristics** (formation, gradient, orientation, accessibility),
- **number of inhabitants to be hosted** (100, 250, 400 inhabitants).

These data have been indicated by the research promoter (the National Dep. of Civil Protection) on the basis of the acquired experience.

For the application of data to the context, a matrix system is used to synthesize the multiple situations which the urban planner may face during the projecting of the Transitional Housing Settlement (in the pre-emergency or in the emergency phases).

As far as the area characteristics are concerned, the variables are 4:

- *area geometry,*
- *accessibility,*
- *gradient,*
- *orientation.*

By putting into relation the first 2 variables, the solutions so obtained identify the discriminants in terms of geometric properties and accessibility, which may determine the projecting choice for the appropriate Settlement Pattern.

In relation to the area geometry, 2 great categories have been identified, where the multiple projecting situations have been collected:

- extended formation area,
- compact formation area.

The accessibility is a fundamental parameter which can not be set aside. The Settlement Models - described below - are characterized by a strong directional dimension with respect to roading; this feature is strictly put into relation with the area accessibility, which can only be determined when applied to a real case.

By comparing the 2 solutions obtained in terms of geometry (compact formation and extended formation) with the other variables (gradient and orientation) and considered the context accessibility, two matrixes incorporating all the theoretical solutions which may influence the projecting choices are so obtained.

Some of the solutions obtained are not consistent with the project given a series of considerations referring to the predefined requisites (e.g., solarization, ventilation, formation-function ratio), and they have thus been discarded. The implication of this operation is that of progressively restricting the project variables, providing to the designer a series of indications and guidelines which he/she can choose to comply with, according to the specific circumstances.

Another fundamental element in the analysis of the context conditions is the users dimensional threshold, that is the number of potentially hosted inhabitants.

Upon a social and anthropological assessment, but also upon a series of economic and functional considerations, 3 users thresholds have been identified:

- *100 inhabitants,*
- *250 inhabitants,*
- *400 inhabitants.*

The project guidelines and the synthesis of the urban planning parameters which represent the ultimate objective of this research are defined in relation to these thresholds. In the event that, in a real situation, the planner has to find the accommodation for an intermediate number of inhabitants, he/she can obtain the corresponding parameter values from simple interpolation calculations. For the identification of the spatial-geometric model, he/she has to adapt the reference model which mostly matches the context conditions.

### **Housing Settlement Models**

At an urban-territorial level, the relations of spatial organization between Housing System, Community System (square, green area, roads network) and the Services System leads to the identification of 3 distinct **Transitional Housing Settlement Models**.

As it already occurred with the aggregational patterns, we start with a survey on the historical-cultural reference material, mainly represented by the "city-founding historical tradition". The founding city planning provides for an historical repertoire of examples which mostly get closer to the aimed operation: as a matter of fact, the intention is "to found" a human settlement, where the temporariness implies specific aspects which can not be set aside: the alternative usage of the areas, the limitation of the minimal functional spaces, the reversibility of interventions, etc.

In particular, 3 Housing Settlement models have been identified:

- 1. Linear borough structure,**
- 2. Fortress-city or charterhouse structure,**
- 3. Roman Castrum.**

In the urban planning analysis of the historical cities' fabric referred to in the organization of the emergency camps for the purposes of this research, the reading scale has been expanded to examine the ratio between different aggregates within the same urban centre. It is important to understand what is the role of an aggregate in relation to the other ones in the construction of the urban system. The urban system includes several modules (the aggregates) which are differently distributed in function of the housing settlement models applied. The result is the realization of an urban centre, a suburb area and the main cross road axes, creating a multipliable system. In this research, we make reference to housing settlement models for the organization of emergency camps which are inspired by the fundamental planning principles of the historical cities. Through their spontaneous or planned-founding structure, these cities offer to urban architects the basic planning rules for the setting up of the urban fabric. The reference is not carried out at a formal level, but in distribution and functional terms.

**LINEAR BOROUGH:** it is the basic structure typical of the ancient cities' early expansion phase or of small urban aggregates scattered across the territory; the



generating line is represented by a road of great traffic (central axis), connecting the two borough ends. Within the research, along the main rectilinear path, different typologies of aggregates are developed: row housing, court-row housing, and courts, with roads varying in length according to the number of hosted inhabitants.

**FORTRESS CITY:** this typology refers to the fortress-stronghold city structure or to the abbatial/charterhouse city structure, which in the Middle Ages guaranteed a natural defence against the enemy thanks to the protecting walls. The fortress urban typology is characterized by the progressive hierarchized development of the spaces: from the public areas to the semi-public areas, all with specific organizational patterns, along an idealised axis.

**ROMAN CASTRUM:** this is the most ancient urban planning model for a founding city/town and can also fit to territorial difference of level. The Castrum is realised by two generating lines which cross each other perpendicularly and is characterized by a regular physical bordering (the walls or the military valla). Also known as a "chessboard" plan for the construction of regular housing *insulae*, the public area is located at the centre at the crossing point of the two generating lines, while the other city squares are obtained by the "removal" of an insular-square block. An urban aggregate is composed of modules with an internal dialectics between a *centre* and a *suburbs*, an axis, and two ends for each direction, a longitudinal one and a cross-wise one.

Fig. 3 - Transitional Housing Settlement Models

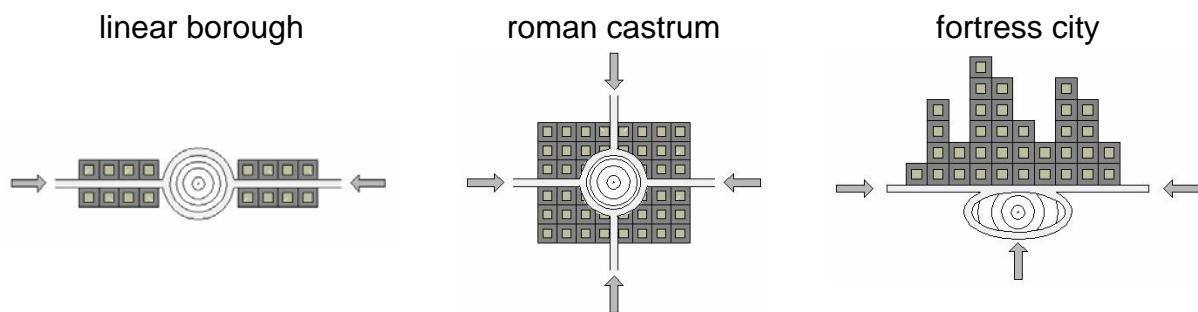

The adaptation of different aggregate typologies, context conditions and housing settlement models is realized through a multi-dimensional matrix which identifies the possible solutions for a transitional settlement on a theoretical basis.

The result is evaluated in terms of feasibility by taking into account the project requisites previously defined. The matching of these elements gives rise to non-consistent solutions (to be rejected on a prior basis), recommendable solutions (where the relationship between the matrix elements is optimal), unrecommendable solutions (where the relationship between the matrix elements presents too many disadvantages), possible solutions (where the results of the matrix elements relations is possible but not optimal).

To sum up, a framework scheme incorporates all the housing hypotheses which may develop at the change of the housing settlement models, the aggregational typologies, the dimensional thresholds. The scheme reports the theoretical housing plans. The relationship between the aggregational typologies (row, court, row-court)

and the context conditions represented in this case by the parameters "gradient – orientation" fatherly identifies the compatibility of the solutions.

### **Project simulation of the settlement configuration for the calculation of the planning parameters**

Upon assessing the compatibility with the context conditions, 12 study cases are examined as examples, which are selected among the recommended solutions. These study cases are the object of a more in-depth projecting simulation.

In support of the parameters calculation for the dimensioning of the transitional settlement, it is necessary to define two instruments categories: on one side, the existing legislative acts in the field of urban planning standards (in particular, the Ministerial Decree n. 1444/68), and on the other, the results obtained from the direct analyses in the field (The Post-Occupancy Evaluation related to the earthquake event in the regions Umbria - Marche of 1997).

This typology of projecting simulation is still a theoretical operation which is too distant from the specifications of the real context. The result is an abstract scheme with geometric and distributional elements, where all components of the Transitional Housing System are defined in quantitative terms and are collocated according to functional relations and social-living factors.

The scheme has a double function: one the hand, that of being a guide to the effective projecting of the transitional settlement; on the other, that of providing (to comply with the research objectives) support to the calculation of the urban parameters related to the transitional settlement. For this purpose, 12 examples of study cases have been selected for the simulation with the intention of providing a general view of the main possible combinations which can be obtained by changing the variables: Housing Settlement Model, Aggregational Typology, Number of hosted inhabitants. The scheme so synthesised thus defines the urban planning standards through a process which, starting from an early dimensional hypothesis based on the existing legislation, is able to adjust the initial value with a retroactive effect, through a geometric-spatial simulation.

The main table of the planning standards underlines how the parameters related to the housing system are indicated in strict relation to the single Minimal Housing Units, while those related to the system of the public spaces (community system and services system) are reported as unit value referred to each inhabitant. This is due to the fact that the housing system composition is based upon the number of houses and to the fact that the number of inhabitants per module can vary within the same Minimal Housing Unit. By contrast, the public services system depends on the aggregation of constant geometric elements.

At the top of the table, the surface value is reported for the Minimal Housing Unit which is kept constant when changing the Housing Settlement Model, the Aggregational Model and the Number of final users to be hosted.

Directly connected with the Minimal Housing Unit are the values defining the Transitional Housing System. These values indicate the percentage/quota of surface per each Housing Unit which are destined to the complementary spaces (neighbourhood unit, green bordering area, parking area, road network). It is

possible to notice how these values are changed upon preliminary projecting choices in terms of housing settlement model and aggregative typology.

As far as the Community System is concerned, the relevant parameters are expressed as surface value per unit per each inhabitant; this value is variable in relation to Housing Settlement Model, Aggregational Typology, Number of users to be hosted.

The Services System parameters are expressed as unit value per each inhabitant and exclusively change on the basis of the dimensional threshold. These parameters are kept constant even if the settlement model and the aggregational typologies change.

The Road Network System is determined by parameterisation per each Minimal Housing Unit when referred to the system of public spaces.

Finally, it is necessary to underline that all the data supplied for the parameters indicate the minimum value under which the housing quality satisfaction is not guaranteed. These data must be interpreted as per mere reference, and not as compulsory instructions. On this respect, at the bottom of the table is the variance range ( $\pm 5\%$ ) for the total surface value associable to the Transitional Housing Settlement as a whole, in function of the real context conditions.

As a guide to the projecting, the instructions here proposed are operational only when applied by the designer who is responsible for emergency relief solutions. The non-aggregate and aggregate numeric figures represent a reference theoretical value as they are the results of a projecting simulation which does not refer to a real context. The effectiveness and consistency of these data depend on evaluations inherent to the overall dimension of the post-disaster area and the real conditions deriving from the combination of the factors characterizing the intervention context (area formation, orography, orientation, accessibility, etc.)

The observance of the parameters depends on the designer in charge of the intervention, who has to consider the surface availability to be used for this purpose. It is obvious that, under the minimum value indicated, the satisfaction of the project requisites characterizing this typology of transitional settlement can not be guaranteed.

## **APPLICATIVE VERIFICATION**

In order to test the effectiveness of the proposed solutions, in the final phase of the research, a projecting laboratory has been organised with the involvement of 6 Local Municipal Authorities, located in various parts of the Italian territory: Maiano (Friuli), Parma (Emilia Romagna), Fosdinovo, Vicchio (Tuscany), Sansepolcro (Umbria) (Fig. 4), Panni (Puglia). Each of them has indicated the area for emergency relief in case of a catastrophe, as specified in the existing urban planning. On the basis of the context data (supply, territorial characteristics, etc.), the forecast evaluation criteria have been applied and an optimal settlement solution has been identified.

At least from theoretical perspective, all the proposed solutions have demonstrated the reliability of the guidelines both in terms of urban parameters and dimensional standards and in terms of housing settlement models.

The need for an urban planning modular and components-controllable instrument has led to the simulation of a calculation method, as an applicative verification of the

suggested settlement typologies. The information system - tested in the embryonic stage limitedly to the general structure and represented in the form of a procedure sequence - has been designed as a support and guidance instrument for the designer in the formulation of the possible settlement solutions.

The first phase of the suggested procedure only implies the selection of models and the dimensional calculation of some component parts. In the second one, the choices and the quantities identified in the first phase are associated to the relevant urban planning parameters. The last phase is the synthesis of all standards, the adaptation of all the measure units previously diversified, with the objective of obtaining an indication on the quantity of total surface required for the transitional settlement.

This verification procedure still needs to improve and represents an early stage of support to the designer who can now rapidly simulate different solutions as well as operating a first selection of the project in view of the area overall dimensions, which must match the available surface.

Fig. 4 - The application of the guidelines to the Municipality of Sansepolcro (Umbria)

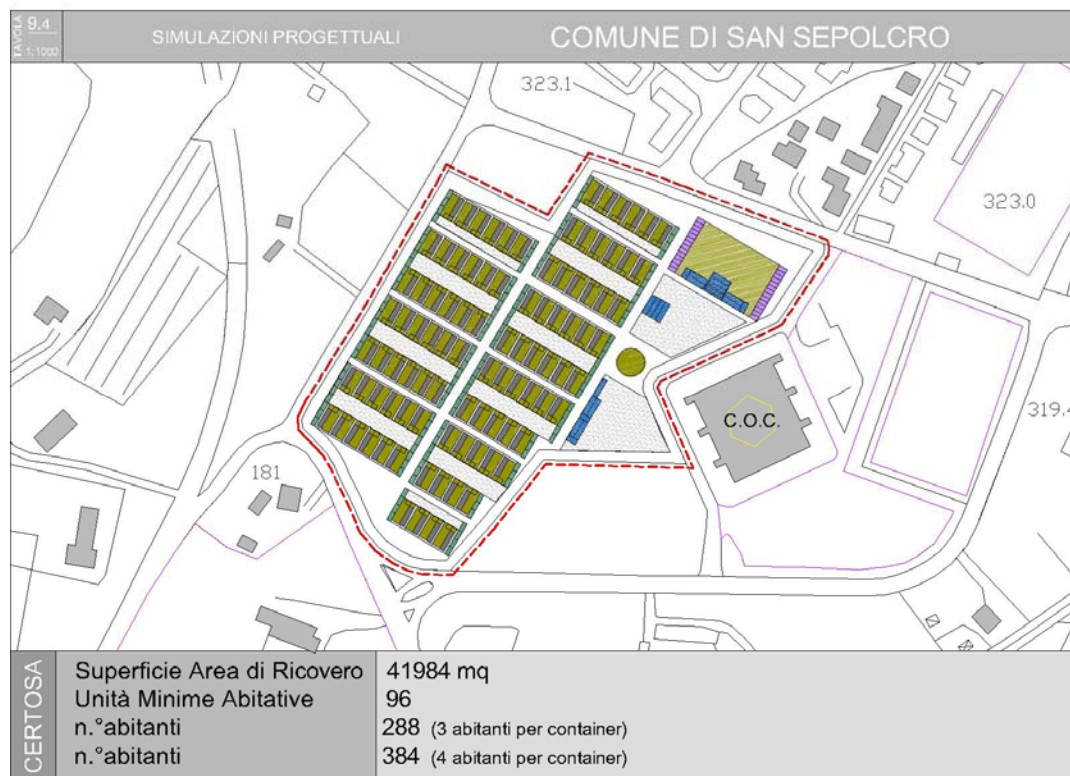

## CONCLUSIONS AND PROSPECTIVES

The first objective of these guidelines is to enhance the quality of emergency housing settlements by marking the passage from the condition of precariousness normally associated to the concept of temporariness to a condition of liveability, which tries to meet the ordinary life standards as much as possible even in

transitional conditions. The quality of housing is therefore connected with the supply of adequate dimensional standards for the living and service functions, the improvement of the environmental well-being, the organization and diversification of the usage modalities and space allocation, as well as with the psychological support to the users through the culture of the environmental psychology and the importance of the context social and environmental factors. The concept of temporariness in the emergency intervention must be evaluated considering the alternative usage of the areas, the reversibility criteria of the settlements, the necessity of facing sustainable development issues, the technical and operational feasibility of the operations in relation to the current production resources.

The different approach to the issue if compared to the current practice is evident in the insight analysis of the historical-cultural characteristics of a settlement planning, even though under transitional conditions: the reference to the founding city criteria (in Italy), the aggregation of the housing units and the typical construction of the urban fabric, characterized in Italy by a wide range of space allocation/distribution modalities (private, semi-private, public).

A second objective of these guidelines is to introduce a new way of overcoming the difficulty of choosing the areas to be used as emergency rescue areas, with the intention of enhancing the relations between the transitional settlement and the local territory/urban centres and of acting beforehand in view of a possible catastrophe. This implies to set up all the procedures required to make the rescue-destined areas immediately exploitable.

The research suggests that the selection of the rescue areas in a post-disaster emergency by part of local authorities within the framework of the general territorial and urban planning must not only rely on security criteria as this often implies the identification of marginal areas or areas of low environmental and social value. The selection must also consider the social and psychological factors, as well as the aspects of neighbourhood with the original housing centres, and, above all, the selected area must be exploitable for alternative uses under ordinary conditions or in peacetime; this would justify a huge economic investment required to realize the essential infrastructure.

The advantage of the differentiation of the infrastructure works in permanent and in temporary is multifaceted: it guarantees a constant usage of the area by part of the local population, it allows a high flexibility in the space organization and, then, the re-establishment of ordinary conditions once the emergency situation is over, it prevents the numerous maintenance problems due to the non-usage of the facilities, their abandonment, the operators' negligence, or the detrimental installation of a fencing, which makes the area to be perceived as a dangerous or private area, and, thus, as an inaccessible zone.

The research here set forth is part of a research programme promoted by the National Department of Civil Protection and the Regione Toscana, which provides as a final result the definition of the entire process of transitional housing settlement.

The results acquired in this research phase have positively been received by the National Civil Protection Department, but, above all, by the involved Local Municipal and District Authorities and the Italian Regional Administrations, to which the results

have been presented. The operative instrument has been approved during the Conference of the Regions. According to the Civil Protection central body, this instrument shall become a reference model at a legislative level for all the Local City/Town Authorities which have to face the planning of transitional housing settlements in case of emergency.

Further investigations have been demanded in order to identify - within a sample of Local Authorities - the reference projecting models for the organization and the realization of the rescue and relief area infrastructures.

These investigations - now under definition with the cooperation of the National Department of Civil Protection and the Regione Toscana - shall focus on the identification of the projecting models for the planning of the areas destined to the transitional emergency settlements, favouring an alternative usage of these areas under ordinary conditions, with the following objectives:

- the definition of the area functions during peacetime in consideration of the specific urban planning, social, environmental context and of the existing urban constraints;
- the verification of the options of economic feasibility in the realization of the post-disaster emergency areas;
- the configuration of the primary infrastructure networks (roads, power and water plants, etc.);
- the compatibility with the transitional housing settlement models hypothesised during the research phase 1.

The research outcomes shall constitute an operational guidance instrument useful for the designing of an emergency rescue area. This instrument shall provide for general applicative instructions based on numerous context-related case histories, to be exploited as much as possible. The targeted users of these guidelines are the Local Authorities operators/technicians in charge of the territorial and urban planning. In cooperation with a determined number of these entities, project feasibility verifications shall be carried out.

## **BIBLIOGRAPHIC REFERENCE**

**Bandini, Roberta and Burdisso, Francesca** (1999). *Calamità e assistenza alloggiativi, Definizione delle Linee Guida di Processo per l'Assistenza Alloggiativa e delle Linee Guida di Progettazione del Sistema Insediativi Provvisorio in relazione alla Vulnerabilità Sismica sul territorio nazionale*, Degree paper, Faculty of Architecture, University of Florence.

**Bologna, Roberto and Terpolilli, Carlo** (edited by) (2005). *Emergenza del Progetto, Progetto dell'Emergenza. Architetture ConTemporaneità*, Federico Motta, Milan.

**Bologna, Roberto** (edited by) (2002). *La reversibilità del costruire*, Maggioli, Rimini.

**Bologna, Roberto** (2001). *Il concetto di transitorietà in una prospettiva sostenibile: Studio di un modello abitativo transitorio e reversibile*, Research report, (Dep. Of Architectural and Design Technologies).

**Caniggia, Gianfranco and Maffei, Gian Luigi** (1999). *Lettura dell'edilizia di base*, Marsilio, Venice.

- Caniggia, Gianfranco and Maffei, Gian Luigi** (1996). *Il progetto nell'edilizia di base*, Marsilio, Venice.
- Caniggia, Gianfranco and Maffei, Gian Luigi** (1979). *Composizione architettonica e tipologia edilizia*, Marsilio, Venice.
- Chiappi, Carlo and Villa, Giorgio** (1980). *Tipo, progetto, composizione architettonica*, Alinea, Florence.
- Geddes, Patrick** (1970). *Città in evoluzione*, Il saggiatore, Milan.
- Klein, Alexander** (1975). *Lo studio delle piante e la progettazione degli spazi negli alloggi minimi: scritti e progetti dal 1906 al 1957*, Mazzotta, Milan.
- Lynch, Kevin** (2001). *L'immagine della città*, Marsilio, Venice.
- Perriccioli, Massimo** (a cura di) (2005). *La temporaneità oltre l'emergenza. Strategie insediative per l'abitare temporaneo*, Kappa, Rome.